

Step 8

NOTE: It may be helpful to have a second person assist in this assembly Step.

Lay the remaining Leg assembly on the floor as shown. Carefully rotate the Shelf Assembly (from Step 7) onto the Leg Assembly.

Loosely attach the Shelf Brackets (on the Additional Shelf) to Hole 2 from the top of the Extension Tubes using three Support Screws per Bracket.

Finally, loosely install three Support Screws into both Shelf Brackets (on the Large Shelf).

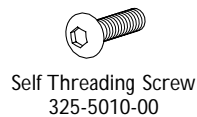
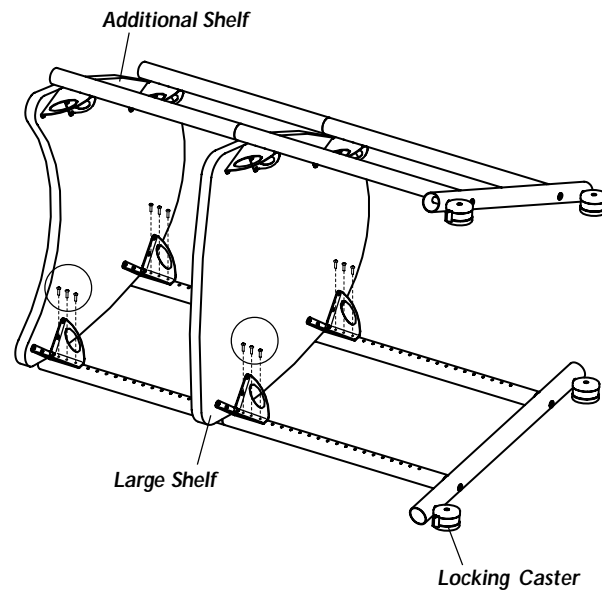

Step 9

Carefully rotate your Cart onto the Castors. Align the Base Bracket with the rear of the Base Tubes. Install one Bracket Screw through each Base Bracket opening into the Base Tube Star Nuts.

Tighten all Support, Base Tube, and Bracket Screws.

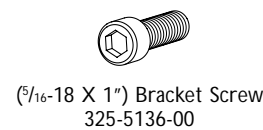
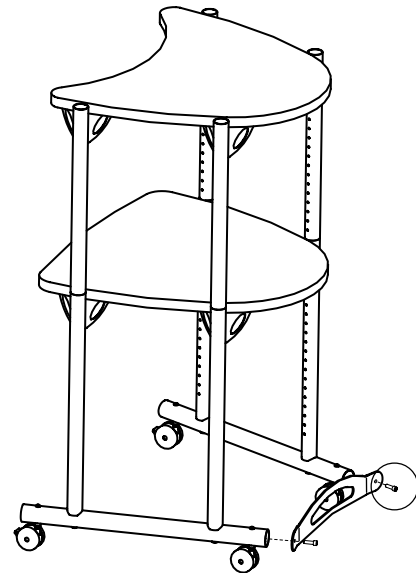

Step 10

Finally, pop the four 1.5" Small End Caps into the Extension Tubes and two 1.75" Large End Caps into the Base Tubes.

Congratulations! Your assembly is complete.

Please return the enclosed Registration Card to receive our product updates, new catalogs, and sale flyers.

Thank you for choosing Anthro!

1.5" Small End Cap

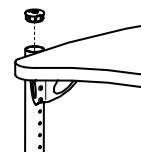

1.75" Large End Cap

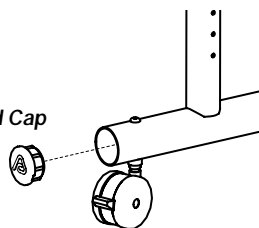

Questions?

1-800-325-3841

Anthro® Space Pal™ (Tall)

Assembly Instructions



TECHNOLOGY FURNITURE®

Questions? 1-800-325-3841

Thank you for buying our Products!

Before beginning assembly of your Anthro Space Pal, please take a moment to review the parts listed below to verify that your shipment is complete.

Additionally, we have included the following items:

Hex Driver ⁵/₃₂" Qty. 1 375-5000-00
 Hex Driver Bit ⁵/₃₂" Qty. 1 375-5003-00
 Hex Key ¹/₄" Qty. 1 375-5024-00
 Wax Stick Qty. 1 175-5034-00
 8 oz. Rubber Mallet Qty. 1 375-5022-00

It may be helpful to have a second person to assist in this assembly procedure.

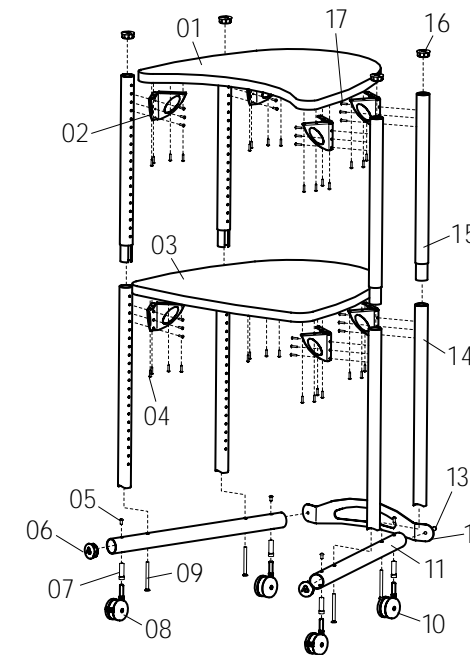
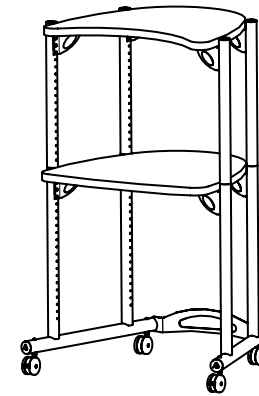

Enclosed Parts List

01- Additional Shelf Qty. 1 100-6366-xx
 02- 3 X 3 Shelf Brackets Qty. 8 225-5397-xx
 03- Large Shelf Qty. 1 100-6365-xx
 04- ³/₄" Wood Screws Qty. 32 325-5106-00
 05- Caster Screws Qty. 4 325-5052-00
 06- 1.75" Large End Caps Qty. 2 175-5021-xx
 07- Caster Inserts Qty. 4 525-1000-00
 08- 2 ³/₈" Locking Casters Qty. 2 150-5003-03
 09- Base Tube Screws Qty. 4 325-5000-00
 10- 2 ³/₈" Non-Locking Casters Qty. 2 150-5002-03
 11- Base Tubes Qty. 2 125-5195-xx

12- Base Bracket Qty. 1 225-5396-xx
 13- Bracket Screws Qty. 2 325-5136-00
 14- 23.875" Vertical Legs Qty. 4 125-5020-xx
 15- 20.1" Extension Tubes Qty. 4 625-5549-xx
 16- 1.5" Small End Caps Qty. 4 175-5020-xx
 17- Support Screws Qty. 24 325-5010-00

Detailed views of all Hardware is provided with each Assembly Step.
All Fastener quantities listed here are the minimum needed for your Cart assembly. There may be a few extra Fasteners included, which are not counted in the Parts List.

Anthro® Space Pal™

Assembly Instructions

Questions? 1-800-325-3841

Step 1

Before proceeding, please review the Assembly Instructions of all Anthro Products you purchased and are planning to include in this installation.

Determine the best height for your Space Pal's Large Shelf. Generally, a 28" high work surface works well for most people and equipment.

These instructions will place your Large Shelf 28" from the floor.

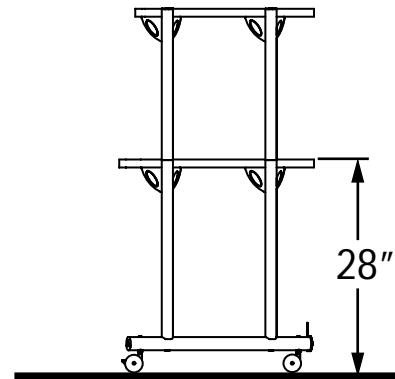

Step 2

Rub the supplied Wax Stick over the Sleeve of each Extension Tube.

Next, Rotate the Extension Tube until the holes line up with those on the Leg then insert the Sleeve into the top of one of the Legs. Repeat for the remaining four Legs.

NOTE: It may be helpful to tap the Extension Tube into the Leg with the Rubber Mallet.

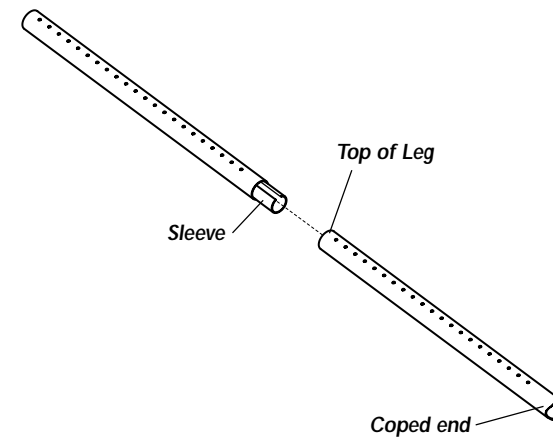

Step 3

Install two Caster Inserts into each Base Tube and secure with one Caster Screw per Insert.

Insert the Casters, (locking ones in front) into the Caster Inserts.

NOTE: Make certain the Base Tube Star Nut is located to the rear as shown.

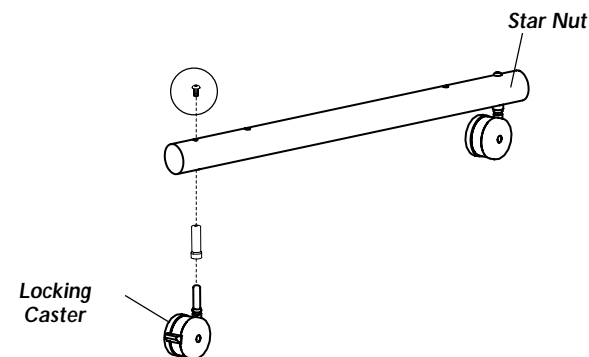

Step 4

Loosely attach two Vertical Legs to each Base Tube assembly (from Step 3) using two Base Tube Screws.

NOTE: Make certain the holes on each of the Legs are oriented with the Base Tubes as shown.

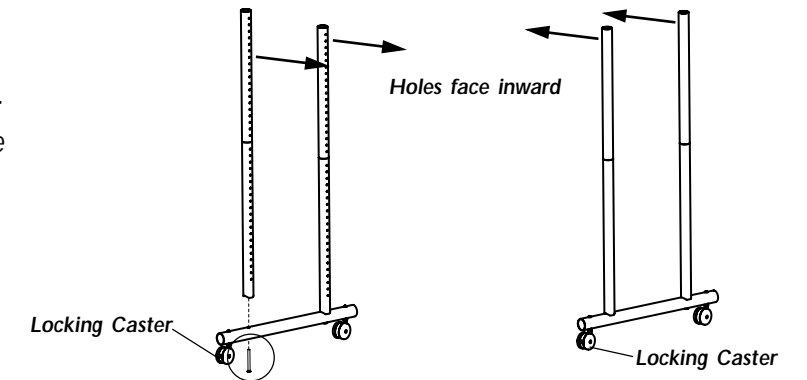

Step 5

Place your Large Shelf with the laminate face down. Align one Shelf Bracket with the four drilled openings as shown. Install four Wood Screws through the Bracket into the Shelf.

Repeat for the remaining seven Shelf Brackets.

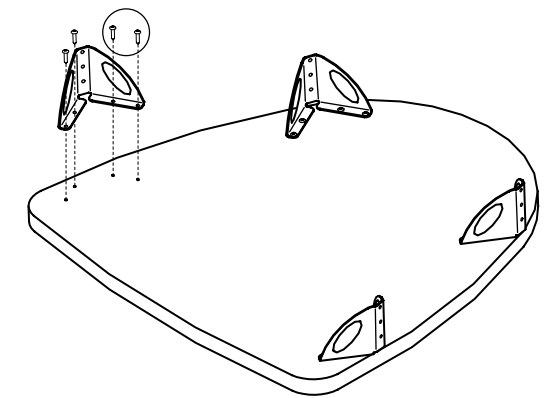
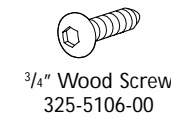

Step 6

Lay one Vertical Leg assembly (from Step 4) onto the floor. Position the Shelf Brackets (on the Large Shelf) with Hole 2 from the top of each Vertical Leg and loosely attach using three Support Screws per Bracket. This will result in a 28" high work surface.

For a Large Shelf final height that is higher or lower than 28", refer to the Leg illustration shown at the far right to determine which hole to attach your Shelf.

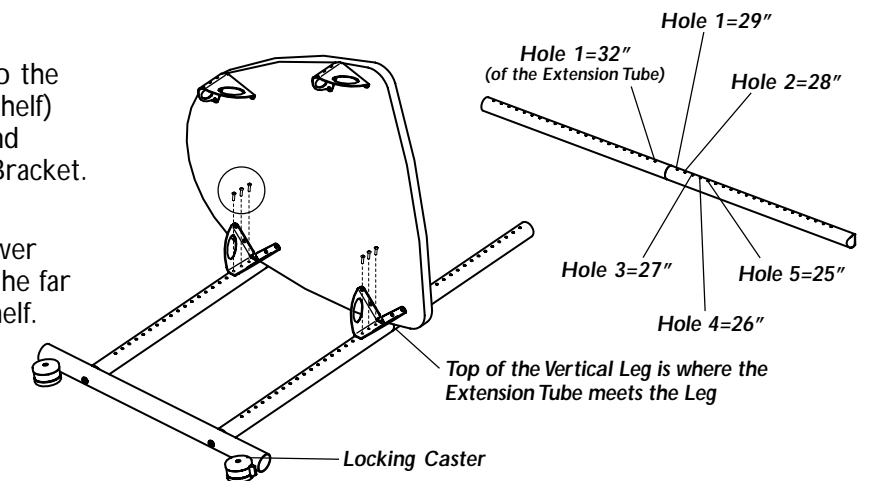

Step 7

Position the Additional Shelf onto the Leg Assembly (from Step 6).

Loosely attach the two Shelf Brackets to Hole 2 from the top of each Extension Tube using three Support Screws per Bracket.

